

# *informs*

21<sup>ST</sup> ISSUE, OCTOBER 2023

## **The sky's the limit**

Everything virtual, automated  
and interconnected.

## **Got the colours - ready, go!**

Do you already work with the  
Meusburger colour codes?

## **From bits and bytes to a precise plate**

You can order from us  
conveniently 24/7 in the  
web shop.



meusburger



# Hello,

*As a reliable supplier in mould and die making, we offer you exactly what you need to realise your projects. Standardisation is the basis for your success. Find out what especially distinguishes us as a standard parts manufacturer and how you can benefit from us in my interview on page 6.*

We are always there for you with our online service. In this year's company magazine, we take you on a journey through our company from order to delivery. Whether it's our web shop, wizards and configurators, automated order processing or digital manufacturing processes, there are many digital processes running in the background to guarantee that ordered products reach their destination as fast as possible. Find out about our new Meusburger portal and the digital advantages we offer on page 12.

You will also get a closer look at our coordinated product range. We offer plates, a wide range of components such as guides, ejectors and much more! Despite steady growth, we remain true to our strong roots and continue to focus on our core area of standard parts. For instance, turn to page 26 to learn about our blocks for eroding.

I hope you enjoy reading the exciting new edition of our company magazine 'informs' and I look forward to continuing our work together in the future.



*S. Meusburger*

Managing Director





*We take  
you on ...*

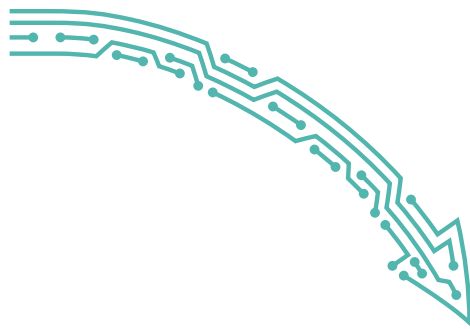

*... the journey  
of data ...*



- 6** Strong as steel in digitalisation
- 8** One click, one story
- 10** The sky's the limit
- 12** Let's talk
- 16** Changing with the times



*... through our  
production ...*

*... all the  
way to you.*

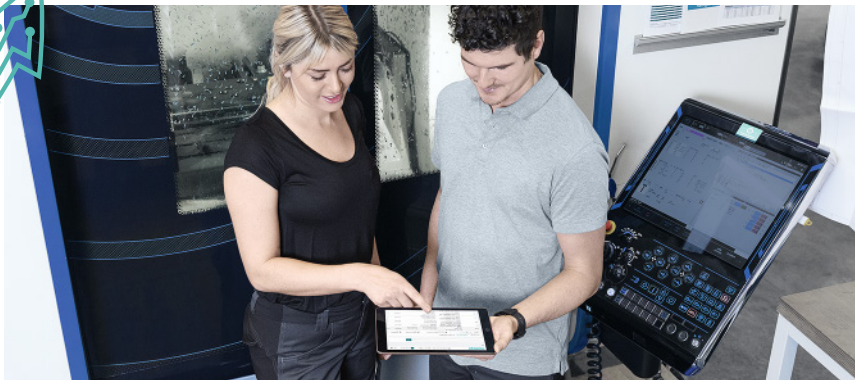

**18** A day with our  
technology managers

**28** From the computer  
directly to the machine

**38** 5 'hot' questions

**20** Order processing at the  
speed of light

**32** From bits and bytes to a  
precise plate

**40** Perfectly networked  
worldwide

**24** Got the colours - ready,  
go!

**34** Automation in the  
warehouse

**44** Did you know ...?

**26** Blocks for eroding in  
focus

**36** Participate & win

**46** Our events in numbers

**Editorial information – Media owner, editor and publisher:** Meusburger Georg GmbH & Co KG Kesselstr. 42, 6960 Wolfurt, Austria, office@meusburger.com, www.meusburger.com;  
**Editing:** Julia Jakob; **Design:** Justin Wackernell; **Photos:** Julia Heißenberger (Meusburger); S. Broger; B. Hämmerle; stock.adobe.com; shutterstock.com; Freepik;  
**Editorial concept in accordance with § 25 of the Media Act:** Free information for customers, partners and employees; May be reprinted only if source is acknowledged; **Note on gender formulation:** For all the names that are related to people, the chosen wording applies to all genders, even if the masculine form is used for the sake of readability.



# *Strong as steel in digitalisation*

---

***Mr Meusburger, your company is a reliable supplier in mould and die making. How do you guarantee that your customers get the products they order on time?***

When a customer places an order with us, many digital processes run behind the scenes to make sure that the product reaches its destination as quickly as possible. You will find out more about these processes in this company magazine. The customer will find a clear overview of their order in the new 'My account' area in our Meusburger portal as well as numerous product information pages, tips, videos, CAD data and much more. The Meusburger shop offers more than 96,000 items, which can be easily adjusted to customer requirements thanks to our wizards and configurators. We have also invested a lot to offer optimal lead times in hot runner and control systems. The two areas were integrated into our collective ERP system. That way offers and orders can be processed even faster throughout the company.

***Besides all of the digital processes – what about Meusburger's product range sets it apart?***

We offer our customers everything they need along the value chain to realise their projects. Our product range is perfectly coordinated to the requirements in mould and die making. We are currently focusing on optimi-

sing the existing areas step by step and rely on standardisation as the basis for our customers' success. Plates have been our core business from the very beginning. Our large standard parts warehouse with over 30 material grades is a huge advantage for our customers and our high percentage of in-house production guarantees the best quality. Besides the comprehensive range of plates, we also offer a large selection of components such as guides, ejectors, slides and much more.

***What would you describe as your company's greatest strength?***

In addition to our coordinated product range and comprehensive online service, we stand out with our process optimisation and structuring. A key element to our success is our organised method of handling employee knowledge. It is important not to just protect the company-wide know-how but to actively and systematically manage it. That way the same approach can be repeatedly and consistently used to solve problems in the long run. At Meusburger, our knowledge is recorded in knowledge documents using our WIVIO software and is accessible to everyone. This significantly improves and increases everyone's ability to work efficiently. Decisions can be accurately made and orders can be processed faster.



***Meusburger made appearances at many trade fairs again this year and held some events on site at customer premises. Why are events like these so important?***

To be successful in the long term, it is important to maintain existing partnerships within the branch and make new contacts. That way new opportunities always arise. Meusburger was pleased to attend many national and international trade fairs and events again this year. The one-on-one chats and technical discussions with our customers are always something special. We also had some interesting events at our Vorarlberg locations this year, such as our Designer's Meeting in March, the Mould Making Industry Meeting in April and the Italian Days in May. This was the optimal plat-

form for our customers to find out about new ideas and trends in the industry and expand their network. A diverse programme with a variety of lectures, company tours and great evening events was offered both at the Hohenems and Wolfurt locations. Our customers are always welcome to visit us in Vorarlberg to take a look behind the scenes at Meusburger. We are organising some exciting events to celebrate 60 years of Meusburger next year. So you can look forward to what's to come.

***Thank you very much for the interview.***

# *One click, one story*

---

*You are scrolling through LinkedIn and suddenly you notice this post. Curious about what Meusburger is up to? One click and you are immersed in the Meusburger online world. Let the story begin ...*

We invite you to join us on a virtual journey. First it leads us to our new portal and on to our digital wizards, with which you can choose your desired product or simply configure it yourself and then complete your order. But then how does the order reach the machines in our production? What other processes does it go through before your package is ready to be shipped?

You will find out that and more on the following pages. Get ready and don't miss out because along the way we will also meet some employees who will tell us about their exciting projects and tasks.

***Dive in now***





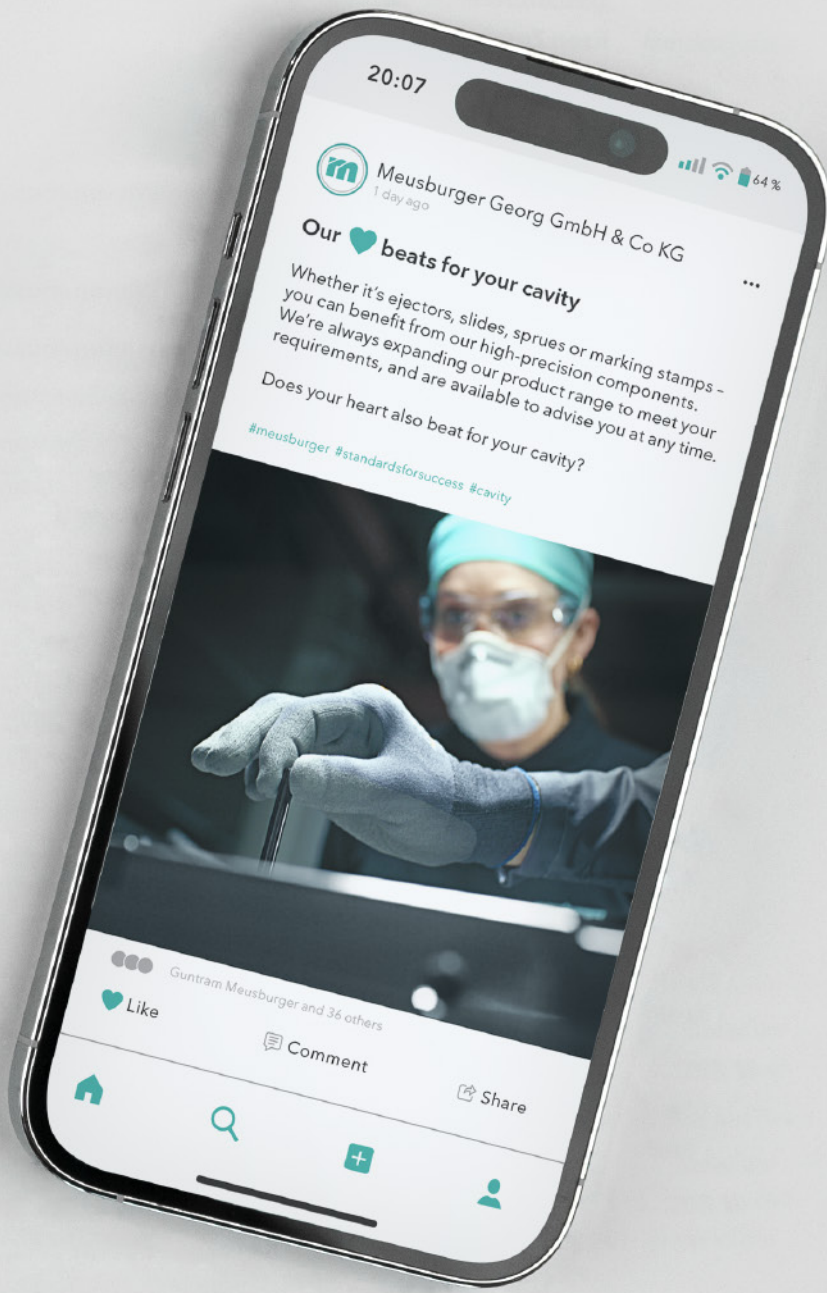

Meusburger Georg GmbH & Co KG  
1 day ago

### Our ❤️ beats for your cavity

Whether it's ejectors, slides, sprues or marking stamps - you can benefit from our high-precision components. We're always expanding our product range to meet your requirements, and are available to advise you at any time.

Does your heart also beat for your cavity?

#meusburger #standardsforsuccess #cavity



Guntram Meusburger and 36 others

Like

Comment

Share



Does your heart beat for your cavity too?  
[www.meusburger.com/cavity](http://www.meusburger.com/cavity)

# The sky's the limit

Everything virtual, automated and interconnected – welcome to the world of digitalisation. Today, it is impossible to imagine daily life without computers, the internet and the like. But who laid the foundation for this? Come with us on a journey into the past.

Current developments are shaping our lives. Terms like 'digital transformation' and 'artificial intelligence' surround us. But what exactly is it all about?

“ We are not only a manufacturer of high-precision standard parts, but also operate one of the largest B2B web shops in Austria.

Thomas Jennerwein, Member of the Executive Board for the IT Division

## Importance for companies:

- + Easier and faster communication
- + More efficient manufacturing processes
- + New business opportunities

At Meusburger we are also taking digitalisation to new heights. We focus on the online service and digital networking of the various areas within the company. That way we are constantly adapting to the needs of our customers – for an even simpler and more efficient ordering process.

It is a pity to waste the time of an intelligent mind with menial arithmetic since anyone can get the right answer with a machine.

# From calculator to artificial intelligence



**1990**

Tim Berners-Lee puts the first website online:  
<http://info.cern.ch/hypertext/WWW/TheProject.html>.  
The World Wide Web is born.

**2023**

We ask ChatGPT to describe itself in one sentence:

*I am ChatGPT, a virtual assistant powered by artificial intelligence and machine learning to answer questions and help with various tasks.*

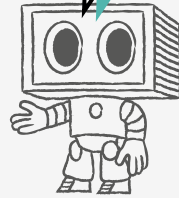

**1971**

Ray Tomlinson sends the first modern email. To do this he creates the world's first email address:  
[tomlinson@bbntenexa](mailto:tomlinson@bbntenexa).

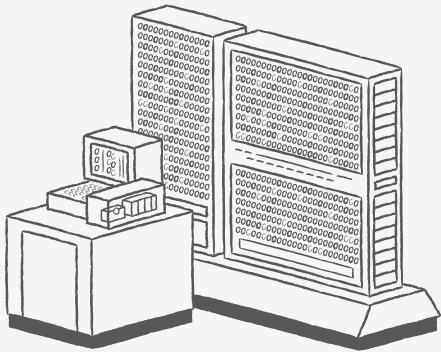

**1941**

Konrad Zuse builds the world's first working computer: the Z3.

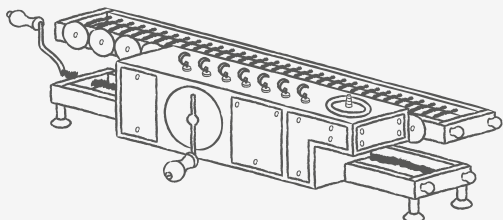

**1837**

Charles Babbage and Ada Lovelace develop the general-purpose computing machine Analytical Engine and are considered the pioneers of the modern universally programmable computer.

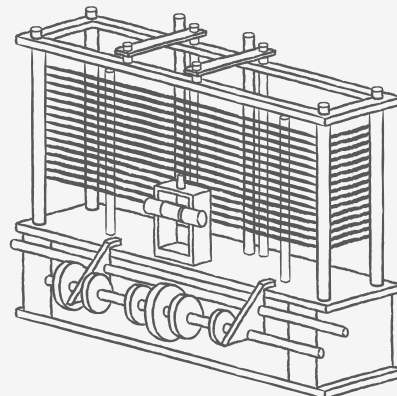

**1673**

Gottfried Wilhelm Leibniz invents the binary system and calculator.

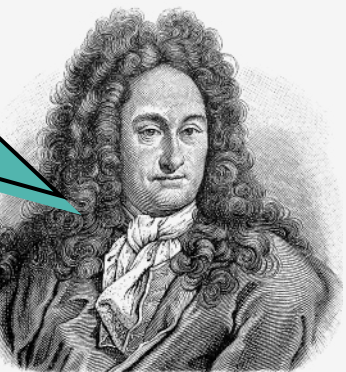

# Let's talk

An outstanding customer experience from first click to delivery. We have been working on a new portal for some time now to make this possible. For an exciting look behind the scenes, we asked Martin Kousek and Stefan Nußbaumer, managers of the largest digital project at Meusburger, five questions.

## Why was the decision to develop a new portal made?

**Martin Kousek:** The technological world is constantly evolving. Our previous system grew over time and so now consists of several separate areas. With the new portal, we offer a consistent, easier-to-use user interface, where data and functions are better interconnected. We are also creating a technical basis that is ready for future developments.

## What excites you personally about the portal?

**Martin Kousek:** There are so many highlights. The 'My account' area offers the greatest customer benefit of the features released so far. It combines a clear design with many new options. For example, it gives customers a complete overview of their order history in just a few clicks. But when I think of what is to come, this is just one of the milestones I am excited about.

**Stefan Nußbaumer:** I would also like to emphasise the great internal, multidisciplinary teamwork. I personally enjoyed working with colleagues with different focuses such as IT, product, marketing and usability. The approach for the project set up works great too. Each customer requirement is elaborately described and a solution is developed for it.

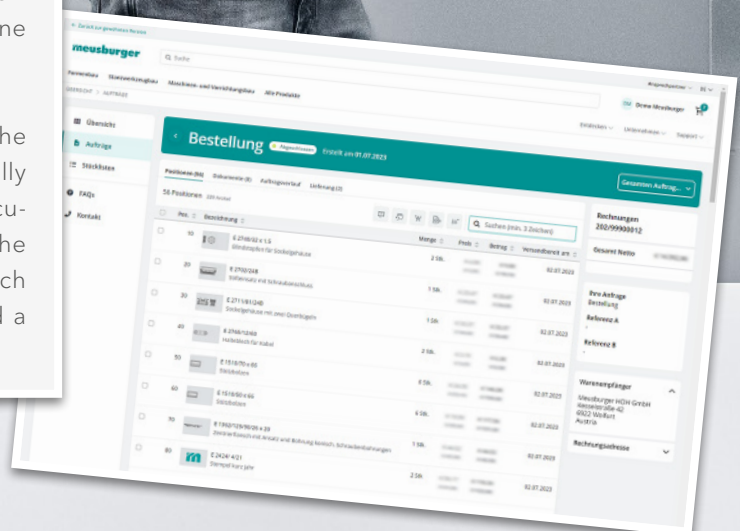

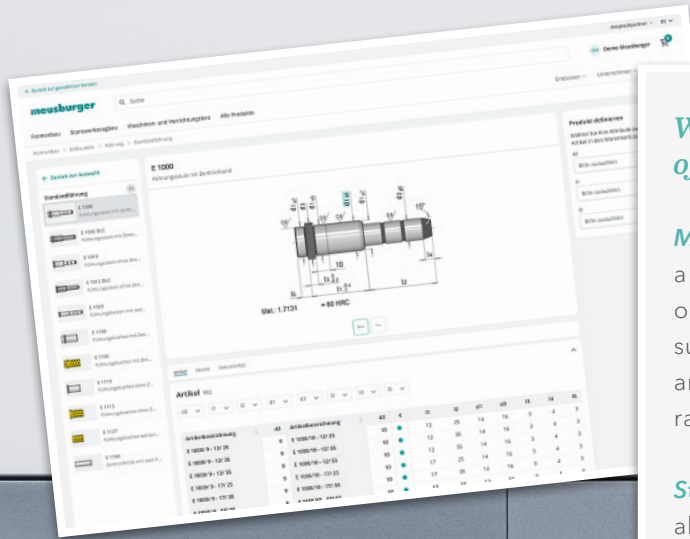

## What advantages does the new development offer the customer?

**Martin Kousek:** The biggest advantage is that we offer a central, overarching portal, with all information in one place. All products are clearly presented with suggested solutions, recommendations, documents and much more. The portal is also optimised for a wide range of devices.

**Stefan Nußbaumer:** The search and filter options have also been greatly improved. That way customers get to the product and ordering faster. The check out process has also been modernised and is state of the art.



## Any impressive figures to show the scope of the project?

**Martin Kousek:** 50,000 active users – that means we are improving our online world for over 50,000 customers.

**Stefan Nußbaumer:** 5 years – from the proposal to go-live. That way we can make sure that everything goes live at a good stage.

## What insider tip can you give customers to use the portal efficiently?

**Stefan Nußbaumer:** For all designers: The new parts lists function offers you many advantages. It means in the future you will be able to make lists quickly and easily – without having to fill a shopping cart. Project-related positions or products can be easily saved.

**Martin Kousek:** Many of the new features are beneficial to all our customers. For example, the shopping cart will always be saved in the future. Older projects and spare parts are also easy to find and order. What's more, the entire support area has many advantages for when questions come up.



# *Cooled compact slide unit*

*For higher quality and very short cycle times*

The E 3380 cooled compact slide unit with long stroke and extremely compact design guarantees excellent results in injection moulding and very short cycle times.



**See for yourself:**  
[www.meusburger.com/E3380-en](http://www.meusburger.com/E3380-en)

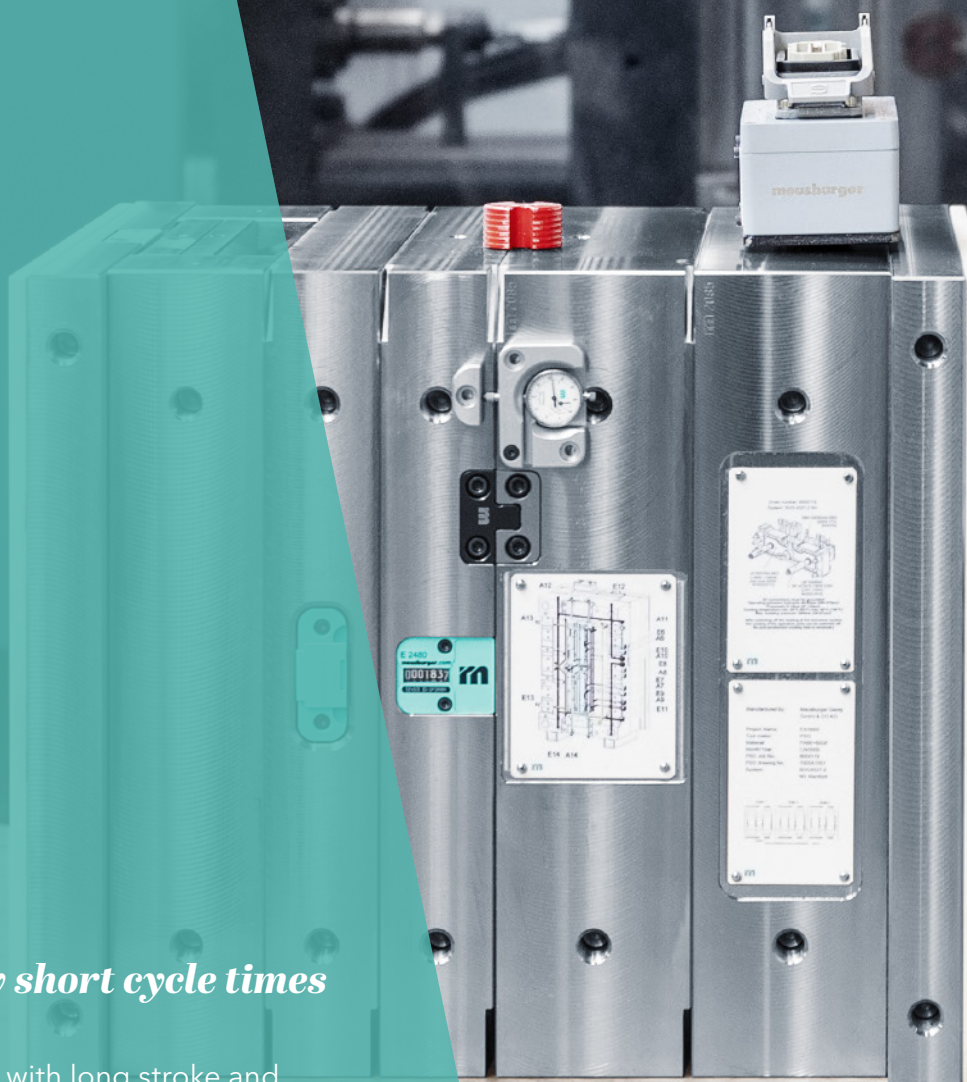



# Changing with the times

Our web shop offers you many important advantages. Since its launch in 2001, we have invested a great amount of time and effort in the advancement of the shop to guarantee simple order processing and user-friendly handling. Take a trip back in time with us and experience the development of our web shop.

2001



- ▶ The first launch of the Meusburger web shop: A 3D data connection as well as the automatic calculation of components are included right from the start.



2010 + 2011



- ▶ The die making and jigs and fixtures construction areas are added to the web shop.



- ▶ Wizards (sliding core and change moulds)

2016

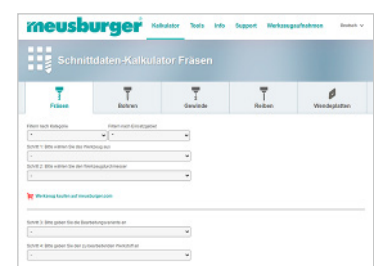

- ▶ Wizards (gas springs, cutting data)

## Loading ...

2005



- ▶ Customer-specific prices can be displayed in the shopping cart.



2013 + 2014



- ▶ The configuration of 3D data directly in the web shop is possible.



- ▶ Wizards (H 1000, two-pillar die sets, labels)



## 2018 + 2019 X

- ▶ The transfer of shopping carts to other users becomes possible.
- ▶ Wizards (latch locks, starting holes in blocks for eroding, hot runner mould)

## 2022 X

- ▶ Wizard (ring plates)



92 %

## 2017 X



- ▶ Go-live of the separate web shop for workshop equipment: However, both shops remain linked to each other by the same login and shopping cart.
- ▶ Wizards (cutting punches, hot runner nozzles, modular concept)

## 2021 X

- ▶ The beta version of 'My account' with functions such as complaint lodging, returns request, direct ordering from a quote and renewed quote request goes online.
- ▶ Wizards (system compression springs, materials)

## 2023 X

- ▶ Wizard (cutting bushes)
- ▶ The web shop and 'My account' are further developed as a part of the Meusburger portal.



As you can see, we stay busy constantly improving our online world for you. So you can look forward to what's to come!

# A day with our technology managers

---

*As technology managers, Markus Jenny and Thomas Enz are the link between product management, sales and subsequently the customers. They give us some insight into their daily work and explain how the product development process at Meusburger works – from the idea to the launch.*

6:30 a.m.: Arrive. Check emails and meetings. Get a coffee. Off we go! That is how the morning generally starts for Markus and Thomas.

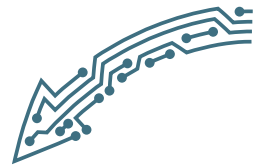

*Markus Jenny, Head of Product Marketing & Event Management / Technology Manager of Mould Making*

*Thomas Enz, Die Making Technology Manager*

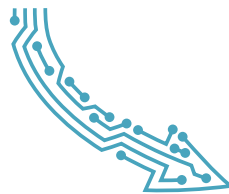

'As technology manager for mould making products, no two days are the same. I work with many different departments and spend a lot of time both in meetings and at my desk. During each product development phase, different tasks are on the agenda,' Markus reports.

Thomas continues: 'Thanks to the clearly defined processes that are accessible to everyone in our knowledge database, all responsibilities are precisely designated. But depending on the scope of the project, development can drag on for six months or even two or three years, sometimes involving more departments, sometimes fewer departments.'

## So how is a new product created at Meusburger?

Markus explains: 'As technology manager, it is first and foremost our job to always look at everything from the customer's perspective where possible. There is a separate platform for idea management in our Intranet. That's where the ideas, especially from customers, sales staff and the product managers, come together.'



For us in die making lots of additional input comes from field engineers who are on site with the customers every day,' adds Thomas.

Both go on to explain that ideas are filtered and evaluated based on established criteria. If the evaluation turns out to be positive, a new project is launched and the actual development process starts. This is where product management takes over. Requirements are specified, designs are made, sketches are drawn and prototypes are created. This is followed by tests and improvements until the final approval of the new product and, if

necessary, a patent application. Product development pays close attention to product-specific requirements and details, such as material properties, mechanical load capacity and much more.

At the same time, coordination is already under way with sales and marketing, especially the online team.

'Everything is always prepared so that the product can be ordered online and, when necessary, configured,' explains Markus.



'We provide our customers with CAD data, wizards and selection guides to support them online at any time. Even when the product is on the market, our work is far from finished. Together with product management, we regularly check various key figures and monitor performance. Accordingly, adjustments may be made or measures taken,' Thomas adds.

To strengthen our innovative power, we will further expand product development and product management in the future. This lets us tailor our developments even better to the needs of our customers.

# Order processing at the speed of light

*With our large selection of products, it could be hard to keep track of everything. But with our digital wizards, finding or configuring the perfect product works like a charm. We give you a brief look behind the scenes and show you how this product then ends up with you as quickly as possible.*

Our more than 20 digital helpers cover a wide variety of product groups. That way, we support you every day in finding the right product quickly and easily. If you can't find the right standard item, you can easily configure many items with our wizards. Not only can you customise the product according to your requirements, you receive the price and CAD data directly.

**OVER 620,000 ITEMS  
HAVE ALREADY BEEN  
SELECTED AND  
CONFIGURED WITH  
OUR DIGITAL WIZARDS.**

## Digital expertise in-house

We put in the effort to make sure you are perfectly advised with just a few clicks. Many experts work with us every day to make sure your order processing is even faster.

Meanwhile, lots of customers are already benefiting from these advantages. We send 300-500 items per day that have been digitally configured and ordered. Maybe the next package we send will be to you?

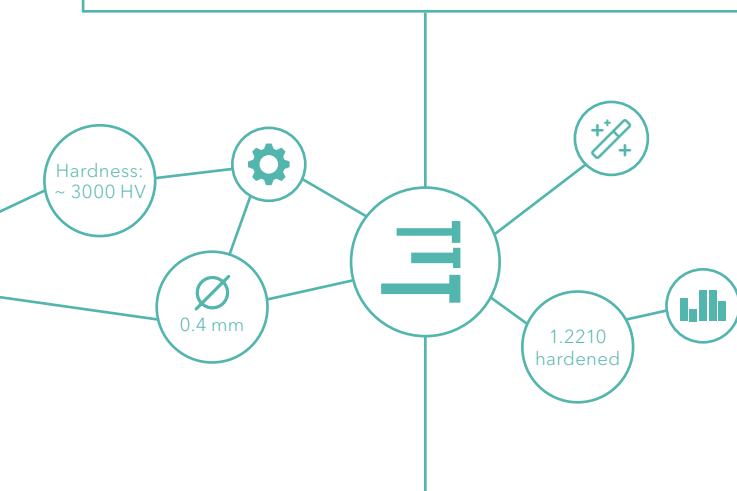

## Efficient ordering

For example, you can customise the length of an ejector. Thanks to our perfectly coordinated internal processes, the data is sent automatically through a wide variety of systems. This means you can see the price for your configured item in seconds. After your order is placed, it goes right to production and is shipped as quickly as possible.

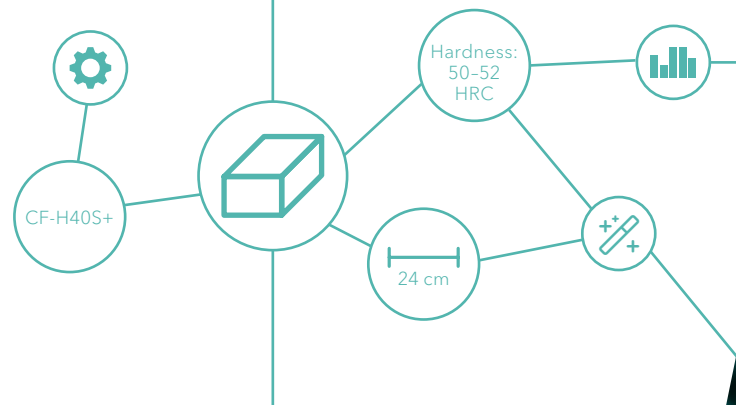

## Optimised manufacturing

Through our algorithm, the optimal raw material is also selected for the special dimensions of plates. That way material usage is optimised and waste is minimised. In addition, the processing time in production is reduced so we can deliver the products to you even faster.

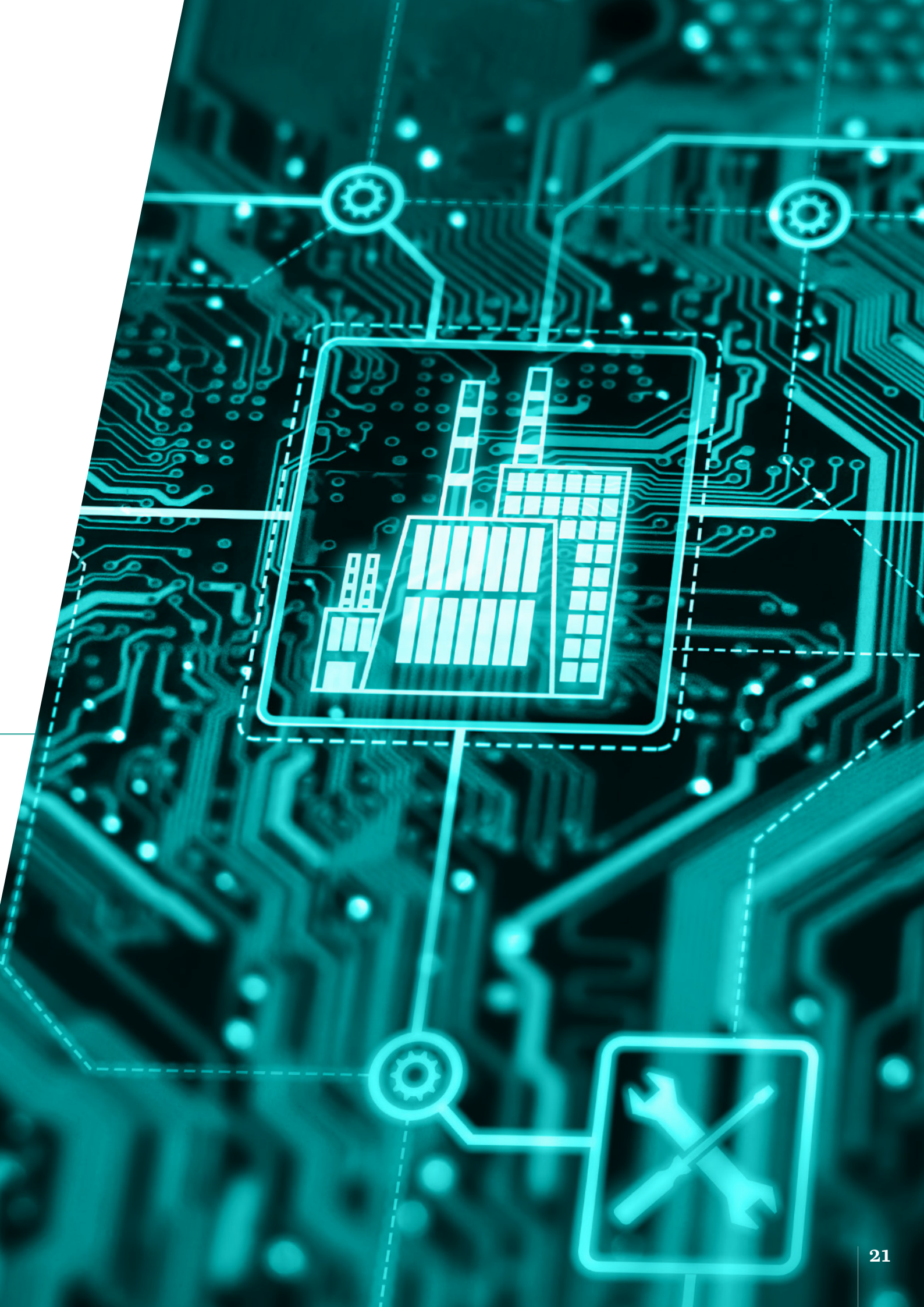





# *Custom-made components*

*Fast offer*

*Fast order processing*

*Usual high quality*

*Guaranteed spare parts*

At Meusburger, we stand for standardised parts. This standard is the basis for your sustainable and economically successful business. If standard doesn't work for you, though, we also offer many components in custom designs.

**Discover now in the web shop:**

[www.meusburger.com/e-special](http://www.meusburger.com/e-special)





# Got the colours – ready, go!

*Do you already work with the Meusburger colour codes? If not, it's about time. Thanks to the standardised colour codes for 3D CAD design, 2D derivations are history. This saves you time and money.*

The tolerances of the Meusburger colour codes are sufficient for your mould base, die set and jigs and fixtures. In most cases, 4 to 5 colours or tolerances are enough.

### Advantages for you:

- ⊕ A quote within the shortest time
- ⊕ Responsible programming
- ⊕ Deadline advantage through optimised processes
- ⊕ No more 2D derivations necessary

CAD-FARBTABELLENSTANDARDS			
CAD COLOUR CODES			
Werkstoff	Werkstoffbezeichnung	Farbe	Anwendungsbereich
1	Alu	Alu	Aluminium
2	St	St	Stahl
3	St	St	Stahl
4	St	St	Stahl
5	St	St	Stahl
6	St	St	Stahl
7	St	St	Stahl
8	St	St	Stahl
9	St	St	Stahl
10	St	St	Stahl
11	St	St	Stahl
12	St	St	Stahl
13	St	St	Stahl
14	St	St	Stahl
15	St	St	Stahl
16	St	St	Stahl
17	St	St	Stahl
18	St	St	Stahl
19	St	St	Stahl
20	St	St	Stahl
21	St	St	Stahl
22	St	St	Stahl
23	St	St	Stahl
24	St	St	Stahl
25	St	St	Stahl
26	St	St	Stahl
27	St	St	Stahl
28	St	St	Stahl
29	St	St	Stahl
30	St	St	Stahl
31	St	St	Stahl
32	St	St	Stahl
33	St	St	Stahl
34	St	St	Stahl
35	St	St	Stahl
36	St	St	Stahl
37	St	St	Stahl
38	St	St	Stahl
39	St	St	Stahl
40	St	St	Stahl
41	St	St	Stahl
42	St	St	Stahl
43	St	St	Stahl
44	St	St	Stahl
45	St	St	Stahl
46	St	St	Stahl
47	St	St	Stahl
48	St	St	Stahl
49	St	St	Stahl
50	St	St	Stahl
51	St	St	Stahl
52	St	St	Stahl
53	St	St	Stahl
54	St	St	Stahl
55	St	St	Stahl
56	St	St	Stahl
57	St	St	Stahl
58	St	St	Stahl
59	St	St	Stahl
60	St	St	Stahl
61	St	St	Stahl
62	St	St	Stahl
63	St	St	Stahl
64	St	St	Stahl
65	St	St	Stahl
66	St	St	Stahl
67	St	St	Stahl
68	St	St	Stahl
69	St	St	Stahl
70	St	St	Stahl
71	St	St	Stahl
72	St	St	Stahl
73	St	St	Stahl
74	St	St	Stahl
75	St	St	Stahl
76	St	St	Stahl
77	St	St	Stahl
78	St	St	Stahl
79	St	St	Stahl
80	St	St	Stahl
81	St	St	Stahl
82	St	St	Stahl
83	St	St	Stahl
84	St	St	Stahl
85	St	St	Stahl
86	St	St	Stahl
87	St	St	Stahl
88	St	St	Stahl
89	St	St	Stahl
90	St	St	Stahl
91	St	St	Stahl
92	St	St	Stahl
93	St	St	Stahl
94	St	St	Stahl
95	St	St	Stahl
96	St	St	Stahl
97	St	St	Stahl
98	St	St	Stahl
99	St	St	Stahl
100	St	St	Stahl

Download now:  
[www.meusburger.com/colour-code](http://www.meusburger.com/colour-code)



- ▶ We work directly from the 3D model.
  - ▶ Each colour stands for a clearly defined tolerance.
  - ▶ The code only contains tolerances that we can manufacture at Meusburger.
- Through the defined colours, tolerances can not only be clearly identified but also recognised and derived by all common CAM systems.

- Bottom**  
RGB 255 | 128 | 0 =  
Tol.: ±0.01
- Diameter**  
RGB 183 | 183 | 220 =  
Tol.: ±0.1
- Thread**  
RGB 255 | 255 | 0 =  
metric thread

(all dimensions given are sample dimensions.)

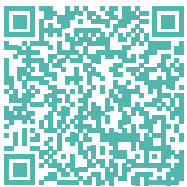
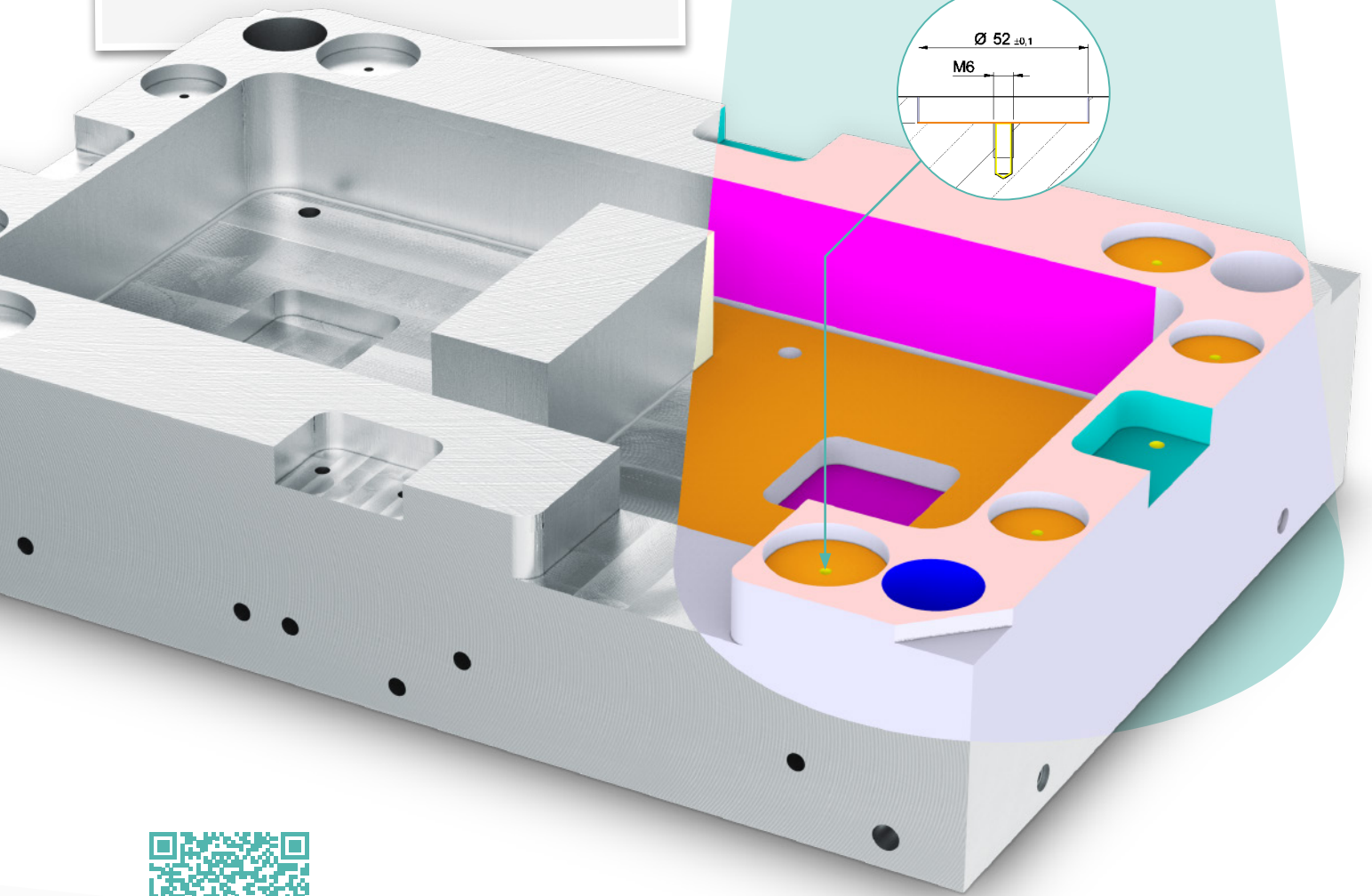
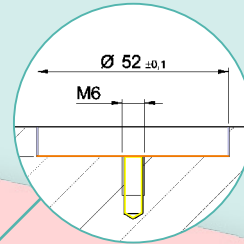

## A look behind the scenes:

Meusburger has been one of the leading suppliers in special machining for almost 60 years. In the Lingenau factory, especially built for special machining, our highly trained professionals work on custom solutions for you.

We show you how in this video.



# Blocks for eroding in focus

---

*At Meusburger we offer a wide range of blocks for eroding that are perfect for active elements and dies and are available from stock. Benefit from great flexibility with our digital tools for starting hole placement and thickness adjustment. To make your choice easier, we have compiled some information and tips for you on blocks for eroding.*

The required EDM contour usually cannot be realised without starting holes which require more work. That's why we offer you the possibility to provide your blocks for eroding with freely positionable starting holes with a diameter of 1 mm in the Meusburger portal.

As usual with Meusburger, the CAD data for your blocks for eroding is also immediately available. That way you can check the position of your starting holes graphically.

You can't find a block for eroding in the right thickness for your needs in our range? No problem: You have the option to easily specify your required thickness in the shopping cart.

You can also have additional information about your special blocks for eroding noted on the delivery note or shipping labels. This makes it easier for you to assign the delivery to the right project so you can get started right away.



*Blocks for eroding are essential for shaping the item to be produced as well as for stamping and forming applications. High requirements must be met, which is why the heat treatment parameters of our blocks for eroding are also adapted to the dimensional range.*

Thomas Enz,  
Die Making Technology Manager



## *Things to know about Meusburger blocks for eroding*

- ⊕ Available in 10 different materials
- ⊕ Cold-work and high-speed steel with defined grain direction
- ⊕ Material name and rolling direction engraved on block for eroding
- ⊕ Heat-treated or hardened and tempered at least 3 times
- ⊕ Deep-frozen if required by the material
- ⊕ Precision ground thickness



# *From the computer directly to the machine*

---

*Can you no longer cover special requirements in-house and need the right solution quickly? This is where we come in, because we are the optimal contact for special machining. Our goal is to offer you the best possible quality and to implement your projects in a way that saves you time and money. How do we guarantee this? You can find out here.*

Do you have a special request in the area of mould and die making or jigs and fixtures construction? No problem - send us the CAD data and we'll get started. This doesn't mean that we do time-consuming programming on the machine, but in advance at our desk with the help of our CAM system. How do you benefit from this?

A major advantage of programming using the CAM system is the significantly better quality of the final product. Not only can we work more accurately and thoroughly, but thanks to the reduced work, we can offer you an optimal price.

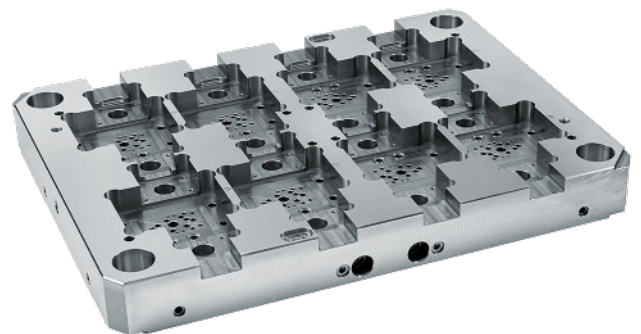
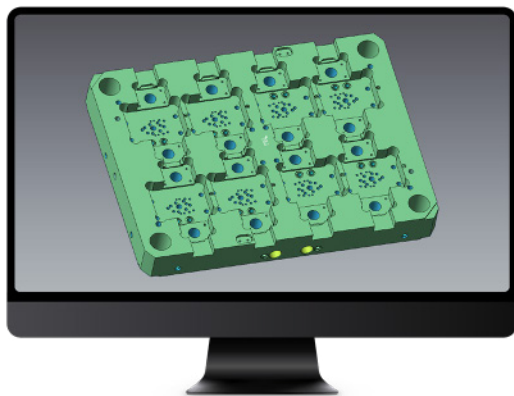

With the help of our CAM system, the required program is created on the computer in the CAM department. The instructions for the machine are in this way directly transferred to production in electronic form. That way we save you the effort of a drawing and facilitate even faster processing. We are able to process all common CAD data. We also use the CAM system for cost calculation and offer preparation in order to be able to send you an offer within the shortest possible time.

By using the CAM system, we are not only much faster but mistakes are avoided since data is taken directly from your 3D model. Moreover, the programme can be checked in advance for collisions and other errors.

# *Multi coupler with EU & USA system*

## *The optimal solution for optimising set-up times*

Often there are long set-up times and unnecessary machine downtimes due to numerous temperature regulation connections. Likewise, possible coupling errors can cause time loss and quality issues. The various multi couplers from Meusburger make it possible to connect the temperature cooling circuits in just one step.



**To the product:**  
[www.meusburger.com/E2871-en](http://www.meusburger.com/E2871-en)

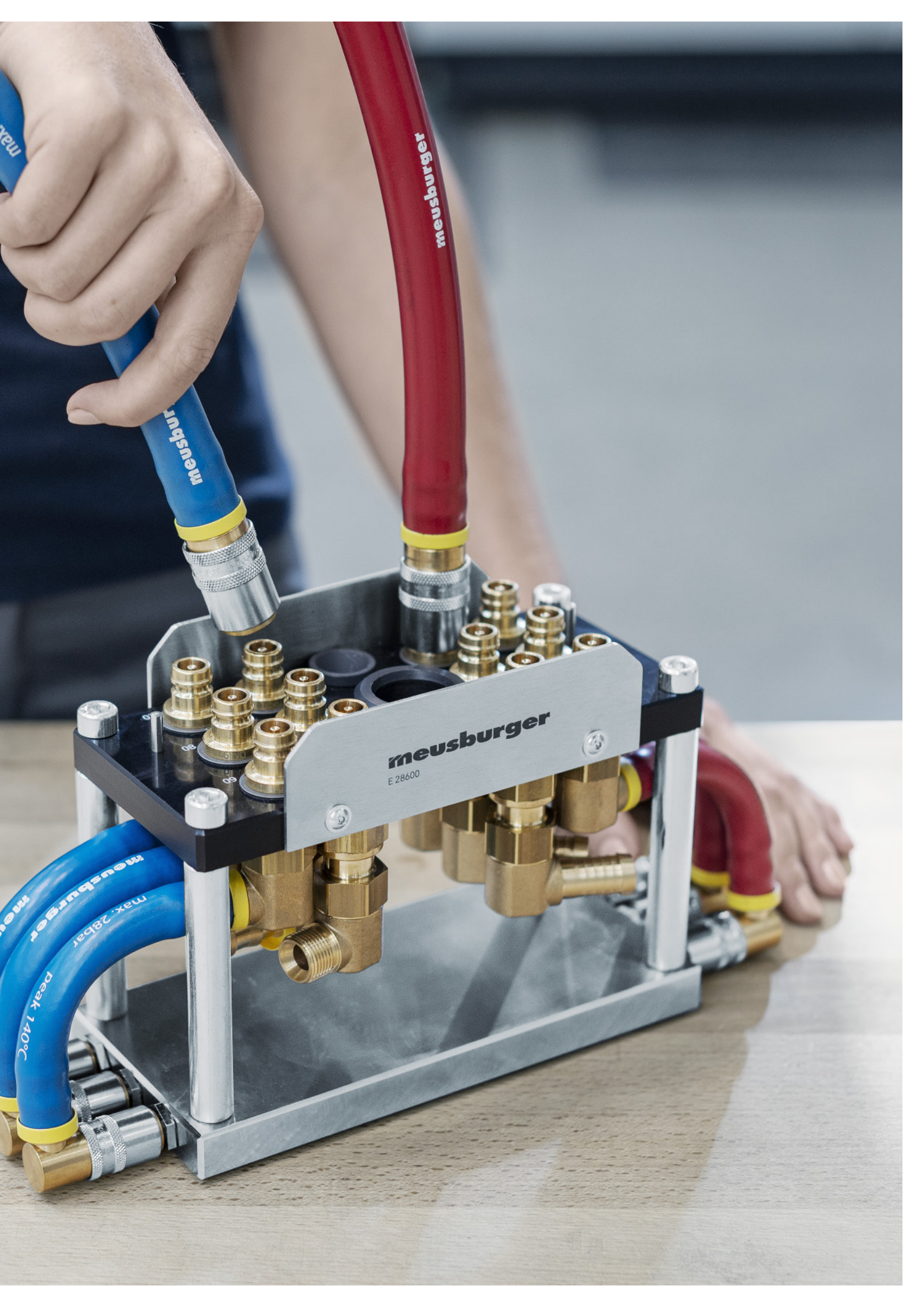

# *From bits and bytes to a precise plate*

---

*You can order from us conveniently 24/7 in the web shop. After just a few clicks your order is submitted. But then what happens? The data begins on an exciting journey, and a multitude of perfectly coordinated processes are set into motion like cogs in a machine. This is how the data packet makes its way from the web shop to production. There the data is transformed into a high-quality product that will soon be on your doorstep. See for yourself ...*



*After just a few clicks your order arrives in production, ...*

01

It all starts in our web shop where you can find your product quickly and easily. Besides standard items available from stock, special dimensions can be ordered in a few clicks.

02

Behind the scenes is a sophisticated system set up by our experts. As a result, the data makes its way through our systems as quickly as possible, and an order is automatically created, checked and approved.

03

The data packet then makes its way directly to production and the machine. Once there, it joins a list.



*... is precisely manufactured  
by our employees ...*



*... and is on its way to you  
shortly thereafter.*

04

05

06

This is where our experienced employees in production select the order. Thanks to the previously created data packet, all set up parameters for the machine are now available digitally.

The employees load the system with our high-quality raw materials, and your plate is produced.

Your product is then inspected, packaged and makes its way directly to you.

# Automation in the warehouse

*Have you always wanted to know how such a variety of our components and workshop equipment gets to you so quickly? Then you've come to the right place – that is our automated small parts warehouse. Go with our HWS 104 power clamp for injection moulding on its journey from this warehouse to the forwarder.*



The storage container with your power clamp is retrieved completely automatically from the warehouse and transported via lifts and roller conveyors to one of the seven order picking stations, where a total of 1,500 items are processed per hour.

The power clamp is waiting for your order at its storage space. As soon as we have received and approved the order, the relevant data is automatically transmitted to our warehouse management system.





Your power clamp is packed securely for transport at the packing station. The finished package is marked with the forwarder's transport labels. For third country shipments, the export documents are prepared and the export is declared.

Your entire order will be loaded right here if it contains only products from the automated small parts warehouse. If this is not the case, your power clamp will be prepared for transport with the rest of your products at another storage location.

At the order picking station the desired quantity of your product is taken from the storage container, marked and placed in the order container. Light signals and grids help to avoid errors. After order picking, the order container is transported to one of the eleven packing stations.

As you can see, your power clamp goes from our warehouse to the forwarder and on to you in no time at all.



**Fact check:**  
**Automated small parts warehouse**

- + Capacity: 65,000 storage spaces
- + 4 aisles
- + 33 levels
- + Storage containers hold up to 50 kg

# Participate & win



# The answer that could win you a holiday

*If you have read this year's edition of 'informs' carefully, one thing is clear: It exists – one answer to all questions. And this answer is the key to your chance to win.*

We are looking for a word that everything in this magazine revolves around. Right at the beginning of the interview, Guntram Meusburger talks about numerous processes that run like this. It continues with wizards that support this and the expertise to do so that we have in-house. There is even an entire article in this issue that focuses solely on this topic.

Do you know what word we are looking for?



Scan the QR code and submit the answer in our online form or go directly to:

[www.meusburger.com/participate](http://www.meusburger.com/participate)

The deadline is **31.12.2023**. Competition results are final and cannot be contested.

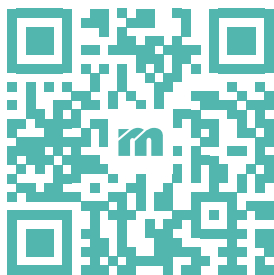

*From the correct answers **two winners** will be drawn to win **2 nights for 2 people** in the **Apartment-Hotel Laurus in Lech am Arlberg**.*

The 4 star hotel is located in the middle of a first-class skiing and hiking area. The apartments offer plenty of space for a wonderful holiday including relaxation in the hotel spa with swimming pool, sauna and steam bath. Participation is definitely worth it!

### *One last tip:*

The words 'virtual', 'automated' or 'networked' could be considered synonyms of the word we're looking for.

# 5 'hot' questions

---

*The area of hot runner systems plays a very important role at Meusburger, since many injection moulding innovations are possible. Our hot runner manager Stefan Kraxner helps us better understand why this is quite a hot topic. He also reveals how the usual Meusburger short delivery times and prompt availability will be ensured in future.*



## *Why are hot runner systems from Meusburger a must?*

We offer a well-designed, streamlined product range that precisely meets market requirements. That way we can guarantee that every customer gets what they need as fast as possible.



## *Doesn't that require a wide selection?*

No. Thanks to our perfectly coordinated standard range in combination with customised hot runner systems, every customer can put together their desired hot runner with us.



## *And how does that work?*

The standardised hot runner components are modular in design and so they can be flexibly combined. The different assembled components can also be modified at any time if necessary. This creates countless opportunities for innovative solutions.

Since these hot runner components are available directly from stock and we have our own machining department and experts in-house, we can respond immediately to any customer request.



## *What is the current highlight in hot runner systems?*

There is already a configurable hot runner mould at Meusburger. That is the EH 6000 hot runner system including a pre-machined mould base, if required, and it can be supplied within 10 working days. The major advantage for the customer is the specially developed configurator, which offers considerable savings in time as well as price transparency.



## *Can you give us an idea of the outlook on further development?*

For hot runner systems, there will always be a mix of standardised and customised solutions. We want to provide our customers with hot runner systems as quickly as possible and, above all, even more cost-effectively. That way, you clearly benefit from the advantages of standardisation without having to forego our comprehensive know-how and individual solutions.



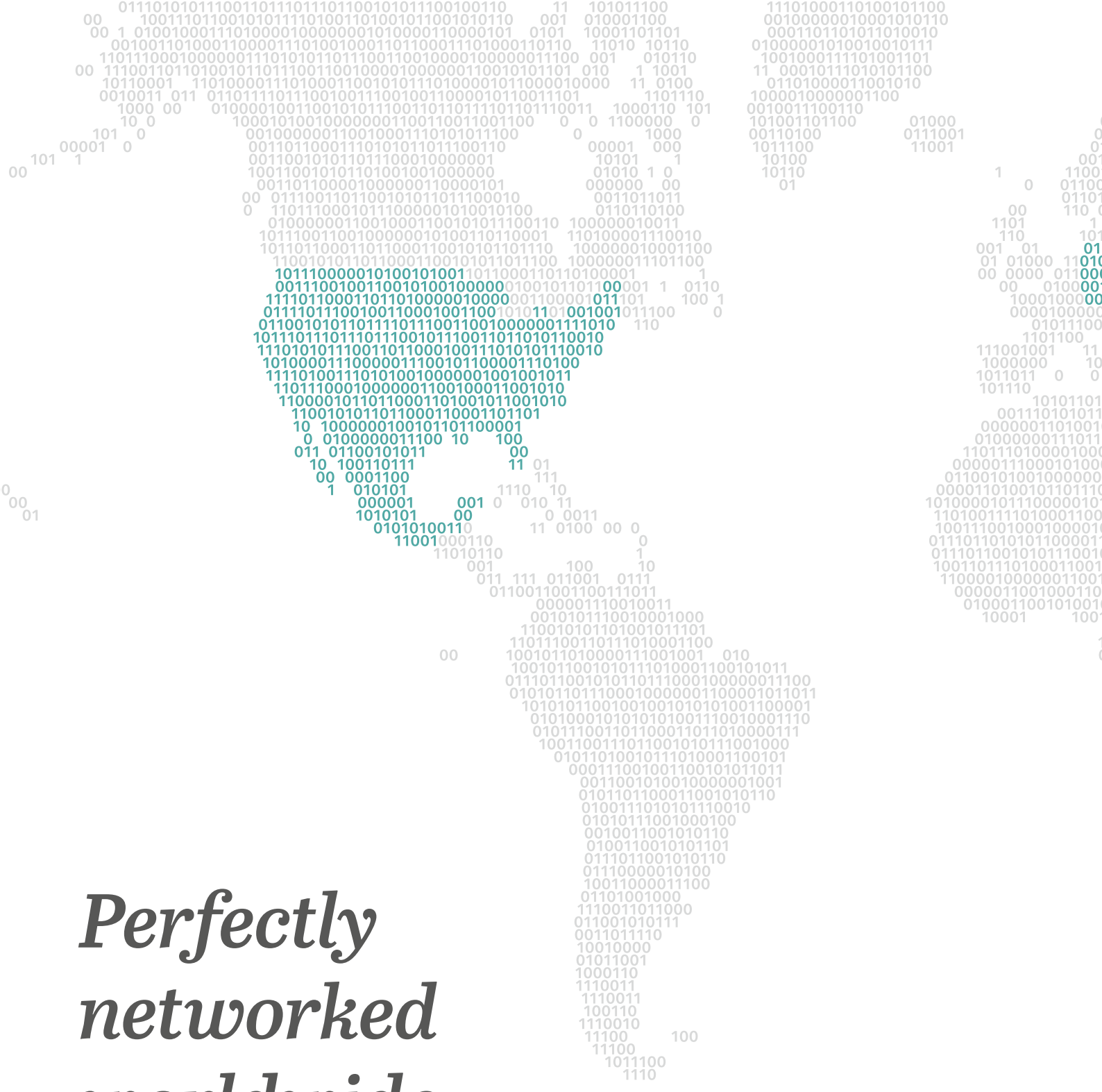

# Perfectly networked worldwide

Besides plates, bars and components, digital networking has been a standard feature at Meusburger for many years. That's why one of our most important goals is to work with the same digital standards at all our locations worldwide, whether it's data security, data protection or business applications. A major milestone this year was the integration of Meusburger Deutschland into our ERP system.

## Meusburger is consolidating

Numerous processes are fully automated at Meusburger to guarantee continuous availability and the fastest possible delivery. We want to offer this automation completely in the hot runner and control systems divisions. The ERP integration of our German locations in Viernheim and Seckach was a foundation stone for this. Last year lots of work went into the necessary preparations. In spring 2023, these areas and thus the two German locations could then be integrated into one shared ERP system.



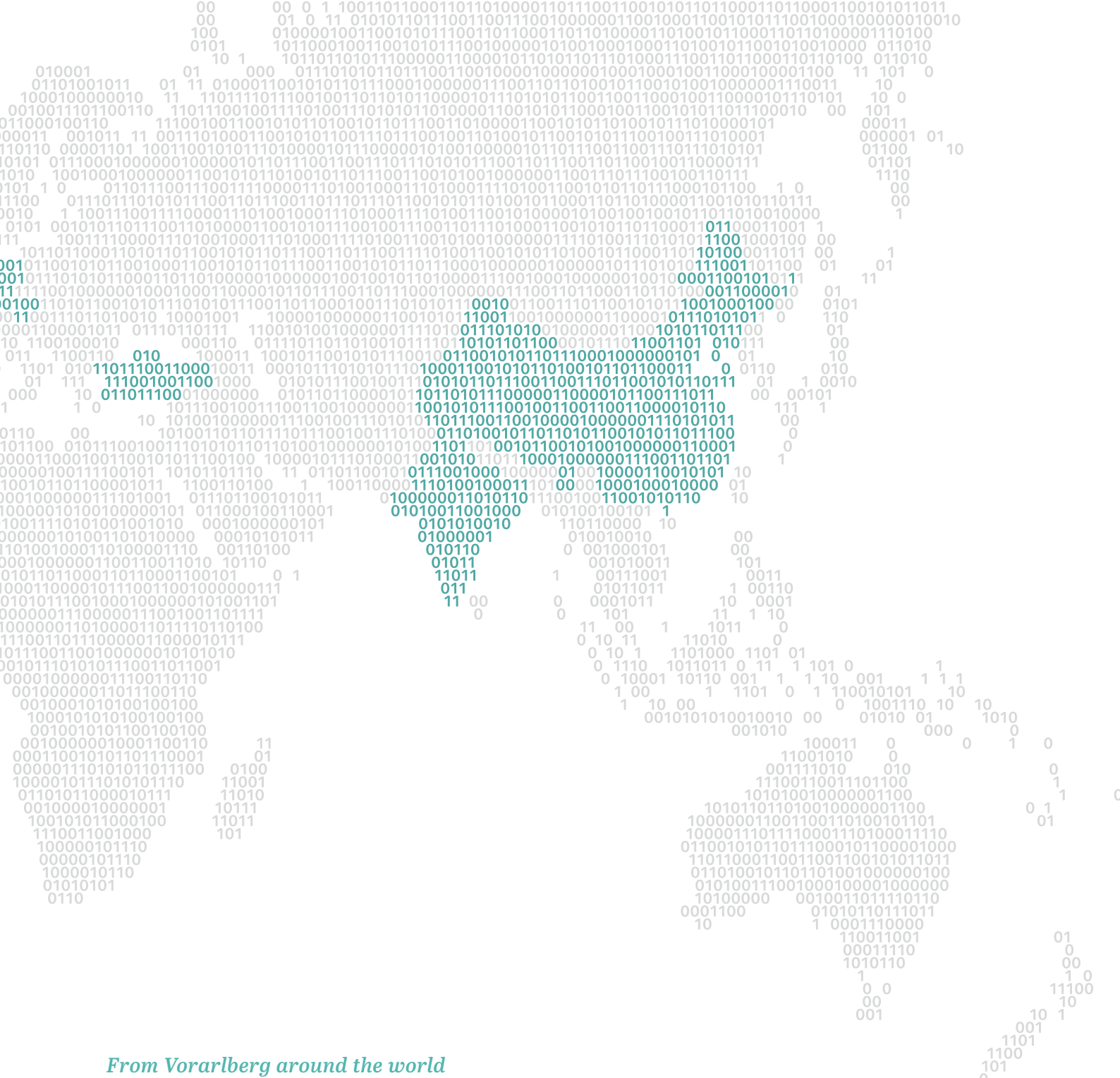

### *From Vorarlberg around the world*

Short lead times and optimum service are two major advantages we offer our customers - no matter where in the world they are. We have succeeded in networking our subsidiary companies in China, India, Mexico, Türkiye and the USA - which all have their own ERP systems - directly with headquarters thanks to specially developed interfaces. That way, everyone works with the same data and in the same processes. This means maximum efficiency and speed for our customers around the world.

In addition to linked systems, we have our own warehouses in China, India and Mexico respectively. That means we can deliver orders to our customers in a very short time just like in Europe.



### *Outlook*

For even better networking, in future all subsidiary companies will be integrated step by step into a common ERP system.





# *Recirculating ball bushing with circlips*

*Unlimited stroke with very compact design*

Benefit from the advantages of our E 1146 recirculating ball bushing with circlips. In combination with our E 1035 and E 1040 guide bolts, guiding without play is guaranteed. The recirculating ball bushing is available from stock ready-to-use.

**Discover now in the web shop:**

[www.meusburger.com/E1146-en](http://www.meusburger.com/E1146-en)



# Did you know ...

... that our training workshop now has its own knowledge management system? 'WIVIO training' includes training content, as well as organisational information and documents.

Using our very own WIVIO software, we are taking a big digital step forward with apprenticeships at Meusburger. This means that all apprentices can now access all their training documents no matter where they are. Information is available to them for each branch of training, which currently include machining technology, mechanical engineering, electrical engineering and mechatronics. Whether they need the apprentice evaluation or want to check the current status of training goals, it's all possible.

'We are pleased that this will allow us to consolidate knowledge on apprentice training in one place and to simplify our processes,' says Dominik Köb, apprentice trainer at Meusburger.

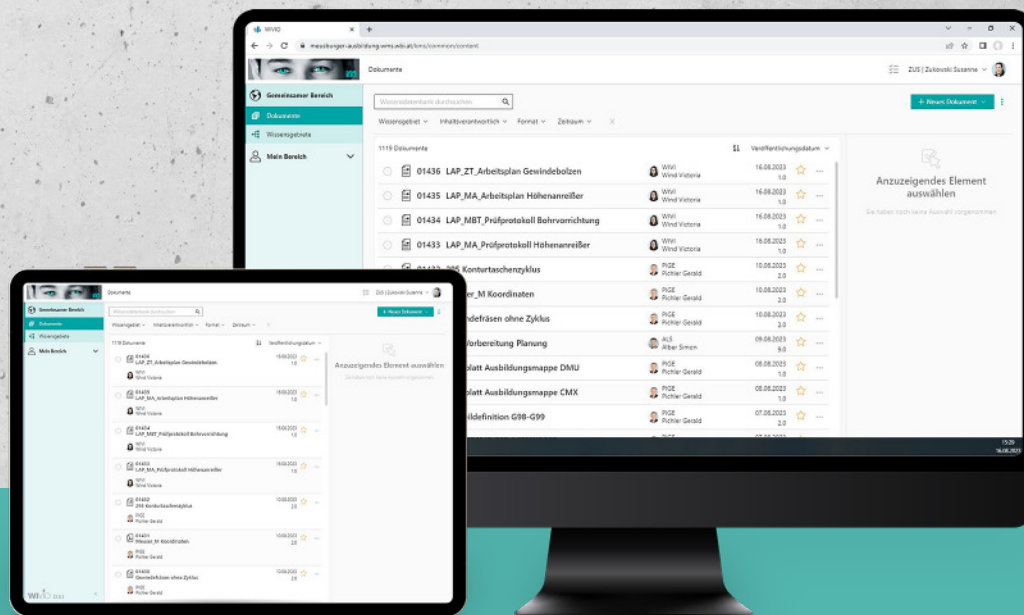

Are you familiar with WIVIO?

The software for managing your knowledge ...  
More information about knowledge management from our partner WBI at: [www.wbi.at](http://www.wbi.at)



# Our events ...

# 2022



# 2023



# ... in numbers

2022

**23** User meetings in customers' regions throughout Europe

**2** Events in Austria with almost 200 participants:  
- Mould making industry meeting in June  
- Die making industry meeting in November

**80** Customers present on average at user meetings

2023

**24** User meetings in customers' regions throughout Europe

**5** Events in Austria:  
- Designer's meeting for Germany/Austria/Switzerland in March  
- Mould making industry meeting for Germany/Austria/Switzerland in April  
- Italian days in May  
- User meetings in September  
- User meetings in November

**100**

Customers per day at internal events



**Don't miss another event!**

Reserve tickets at:

[www.meusburger.com/events](http://www.meusburger.com/events)



